

Chapter 1

Introduction

History of optical fibers

- In the 1840s, physicists Daniel Collodon and Jacques Babinet showed that light could be directed along jets of water for fountain displays.
- In 1854, John Tyndall, a British physicist, demonstrated that light could travel through a curved stream of water thereby proving that a light signal could be bent.
- Alexander Graham Bell patented an optical telephone system called the photophone in 1880.
- French engineer Henry Saint-Rene designed a system of bent glass rods for guiding light

History of optical fibers(cont..)

- During 1930, Heinrich Lamm successfully transmitted and images through a bundle of fibers. The image was of a light bulb filament.
- In 1960s, the LASER was introduced as light source.
- During 1970s, the glass fiber were used for transmission but these fiber have large amount of loss.
- To reduce the losses, the scientists introduced the fiber with different layers (that is the basic structure of fiber).

Basic Communication System

- The communication system is a system which is used for the information exchange between two points.
- The process of transmission and reception of information is called communication.
- The major elements of communication are the **Transmitter** of information, **Channel or medium** of communication and the **Receiver** of information.

Basic Communication System Block Diagram

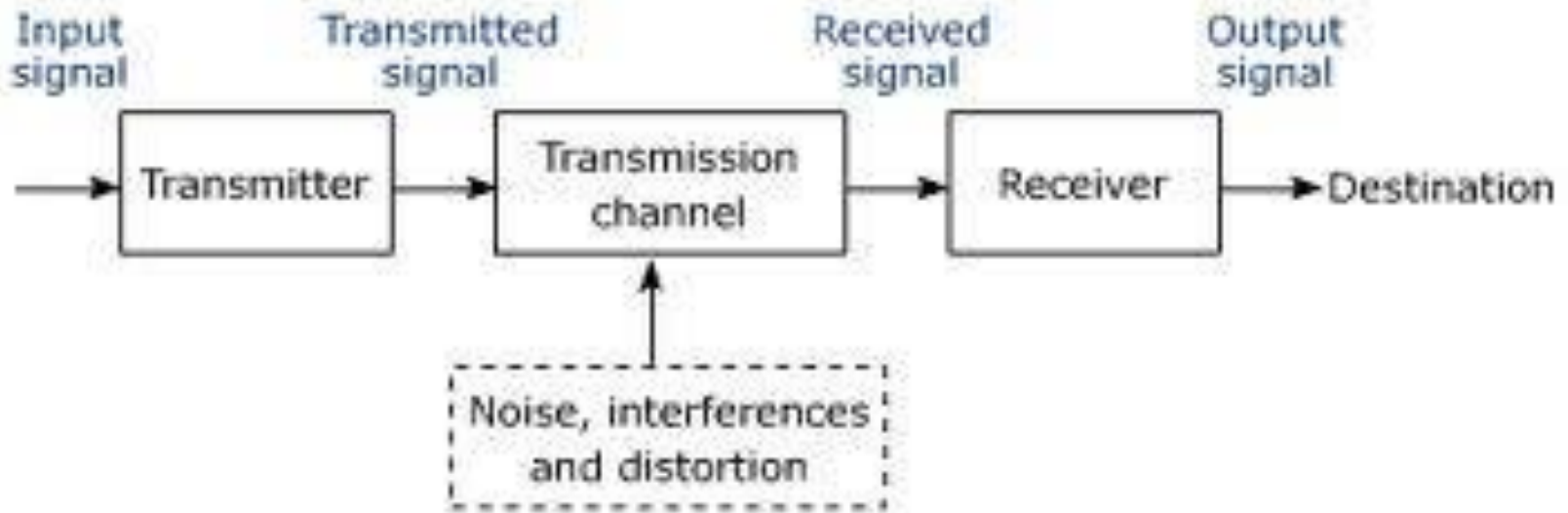

Basic Communication System

- Input Signal: The input signal can be voice, music, Data, Video, Temperature, Light, Pressure etc. the signal that is to be transmitted.
- Transmitter : It converts information into a signal that is suitable for transmission over a medium.
- Channel: A channel in a communication system is the medium through which an information or signal travels from one point to another point.
- Noise: It is the challenge in communication. It is random and unpredictable in nature. Noise is the undesirable energy that enters the communication system and interferes with the desired signal.
- Receiver: It receives the signal (desired) with noise (undesired) and recovers the original signal in spite of the noise.

Optical Frequency Range

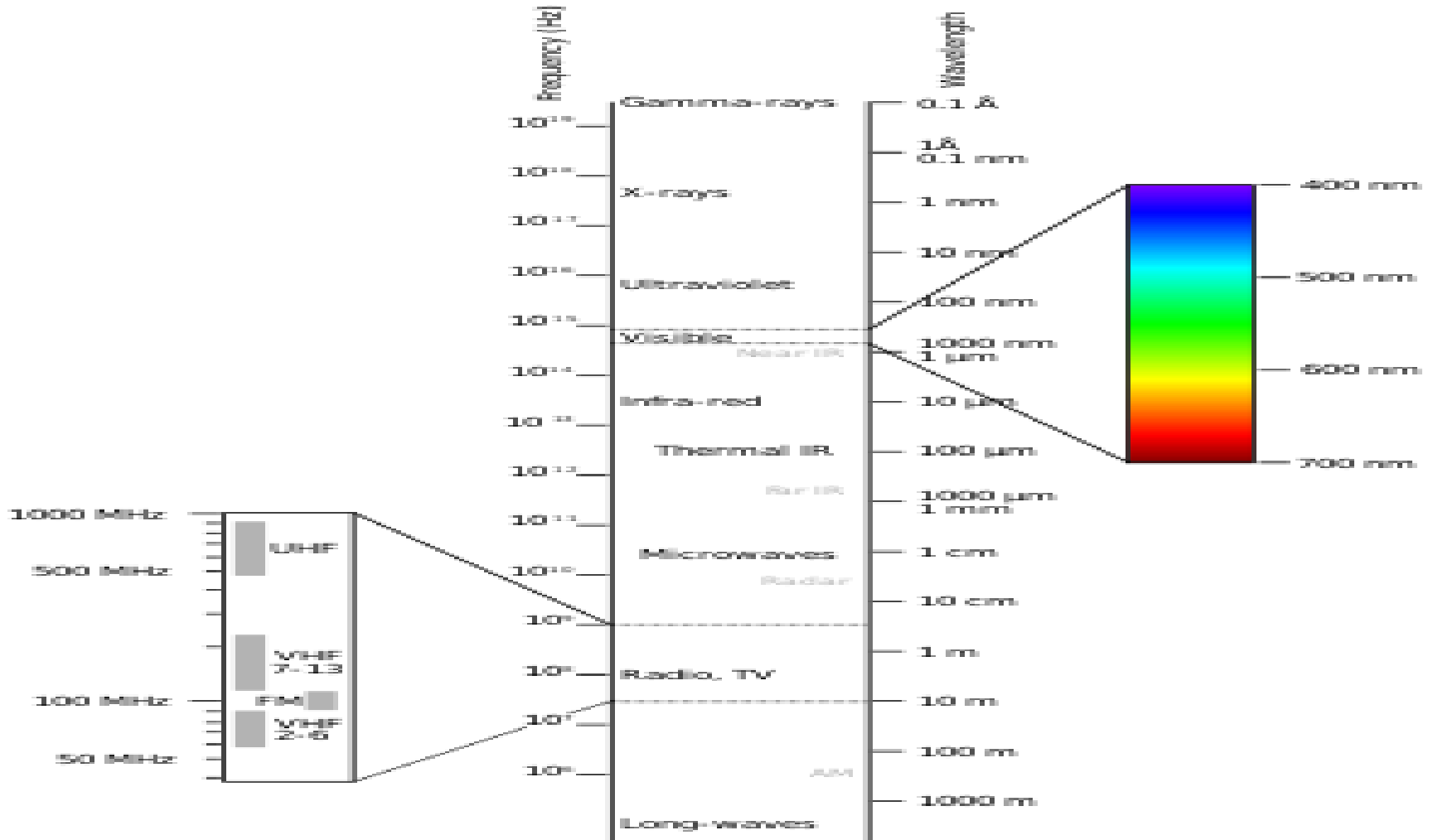

Advantages of Optical fibers

Compared to conventional metal wire (copper wire), optical fibers are:

- 1. Bandwidth:** Fiber optic cables have a much greater bandwidth than metal cables. The amount of information that can be transmitted per unit time of fiber over other transmission media is its most significant advantage.
- 2. Low Power Loss:** An optical fiber offers low power loss, which allows for longer transmission distances. In comparison to copper, in a network, the longest recommended copper distance is 100m while with fiber, it is 2km.
- 3. Interference:** Fiber optic cables are immune to electromagnetic interference. It can also be run in electrically noisy environments without concern as electrical noise will not affect fiber.

Advantages of Optical fibers(cont..)

- 4. Size:** In comparison to copper, a fiber optic cable has nearly 4.5 times as much capacity as the wire cable has and a cross sectional area that is 30 times less.
- 5. Weight:** Fiber optic cables are much thinner and lighter than metal wires. They also occupy less space with cables of the same information capacity. Lighter weight makes fiber easier to install.
- 6. Security:** Optical fibers are difficult to tap. As they do not radiate electromagnetic energy, emissions cannot be intercepted. As physically tapping the fiber takes great skill to do undetected, fiber is the most secure medium available for carrying sensitive data.
- 7. Flexibility:** An optical fiber has greater tensile strength than copper or steel fibers of the same diameter. It is flexible, bends easily and resists most corrosive elements that attack copper cable.

Disadvantages of Optical Fiber Cable

1. **Difficult to Splice:** The optical fibers are difficult to splice, and there are loss of the light in the fiber due to scattering. They have limited physical arc of cables. If you bend them too much, they will break.
2. **Expensive to Install:** The optical fibers are more expensive to install, and they have to be installed by the specialists. They are not as robust as the wires. Special test equipment is often required to the optical fiber.
3. **Highly Susceptible:** The fiber optic cable is a small and compact cable, and it is highly susceptible to becoming cut or damaged during installation or construction activities. The fiber optic cables can provide tremendous data transmission capabilities. So, when the fiber optic cabling is chosen as the transmission medium, it is necessary to address restoration, backup and survivability.
4. The cost of optical fiber per meter is more as compared to copper wire.
5. **Fragile:** The transmission on the optical fiber requires repeating at distance intervals. The fibers can be broken or have transmission losses when wrapped around curves of only a few centimeters radius.

Critical Angle

- Critical angle: The critical angle is the angle of incidence where the angle of refraction is 90° . The light must travel from an optically more dense medium to an optically less dense medium.
- If the angle of incidence is bigger than this critical angle, the refracted ray will not emerge from the medium, but will be reflected back into the medium. This is called **total internal reflection**.
- The critical angle is given by the formula:

$$\theta_c = \sin^{-1}(n_2/n_1)$$

Critical Angle

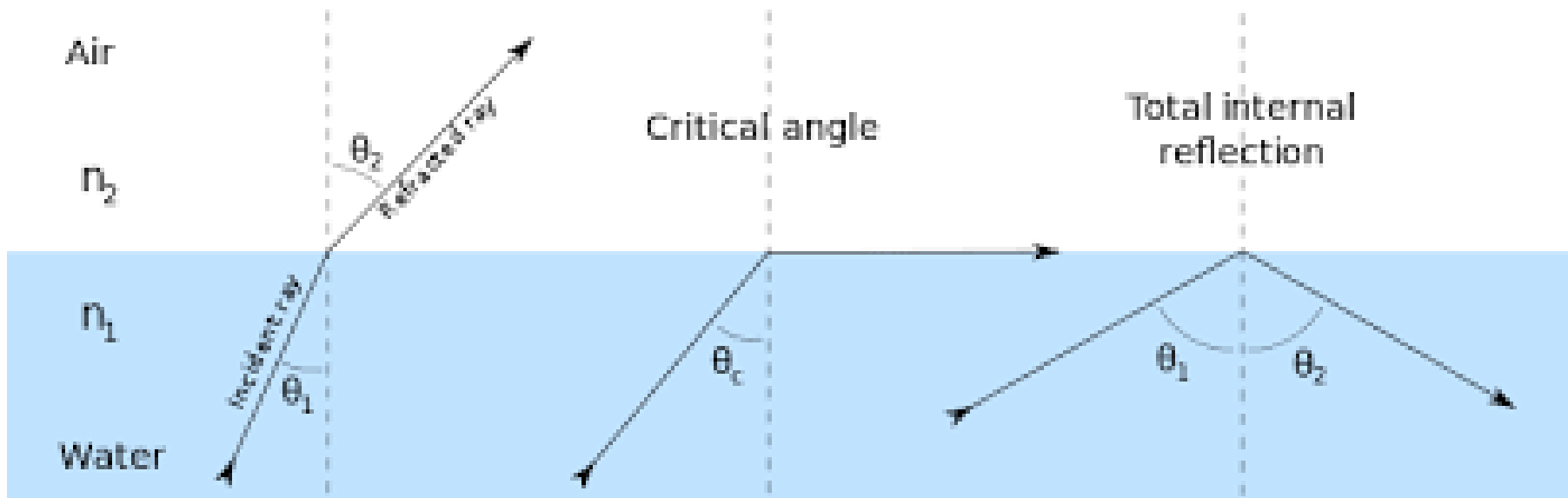

TIR(Total Internal Reflection)

- The principle of light travelling through the fiber is TIR(Total Internal Reflection)
- In an optical fiber, the light travels through the core by constantly reflecting from the cladding because the angle of the light is always greater than the critical angle.
- The conditions for total internal reflection are:
 - light is travelling from an optically denser medium (higher refractive index) to an optically less dense medium (lower refractive index).
 - the angle of incidence is greater than the critical angle.

TOTAL INTERNAL REFLECTION

Angle of incidence less than the critical angle

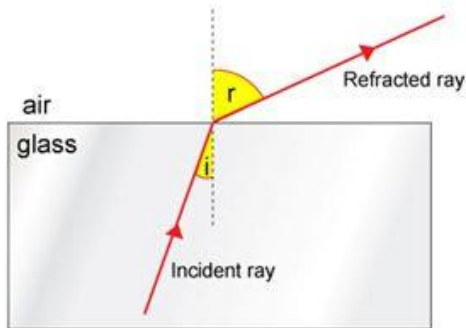

Angle of incidence equal to the critical angle

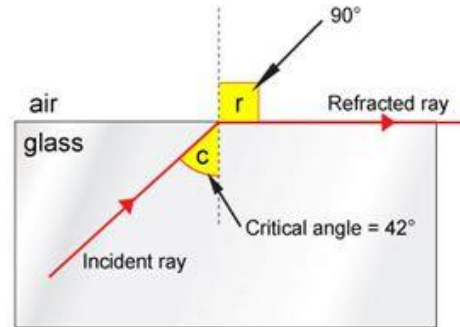

Angle of incidence greater than the critical angle

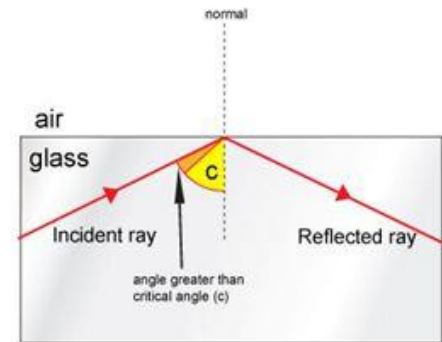

Total internal reflection takes place only when the light travels from denser to rarer medium and angle of incidence should be greater than the critical angle of the denser medium

TIR(Cont..)

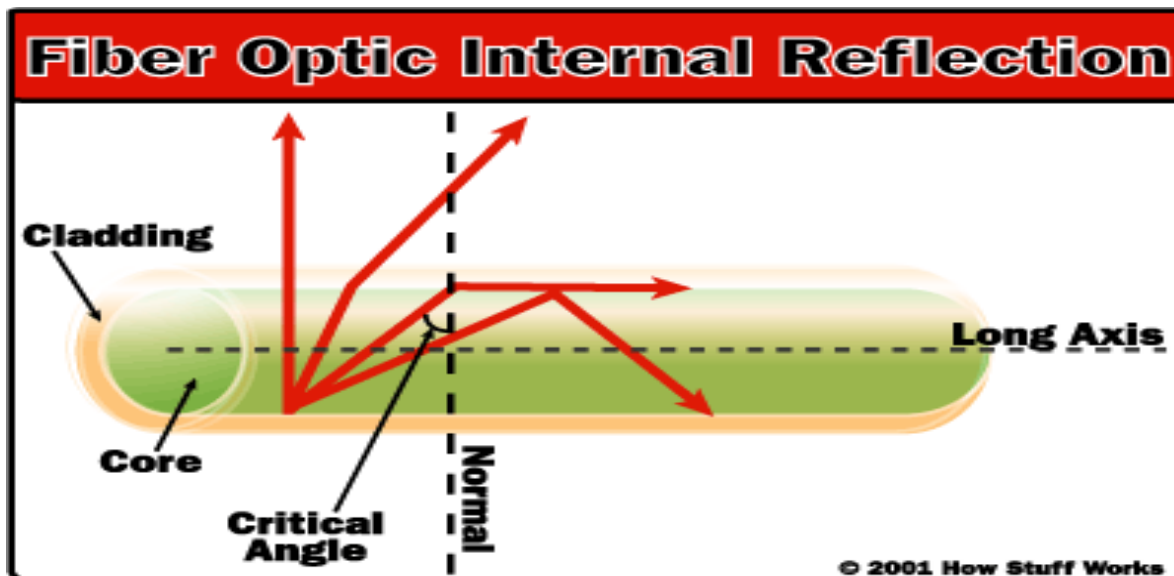
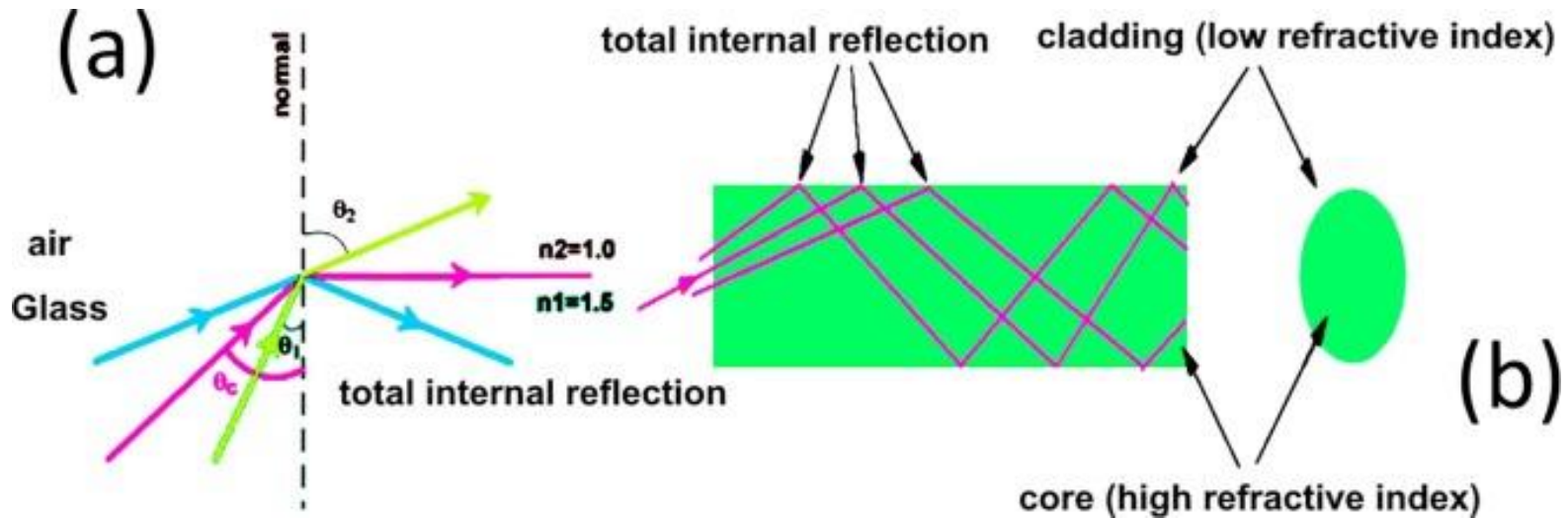

TIR(cont..)

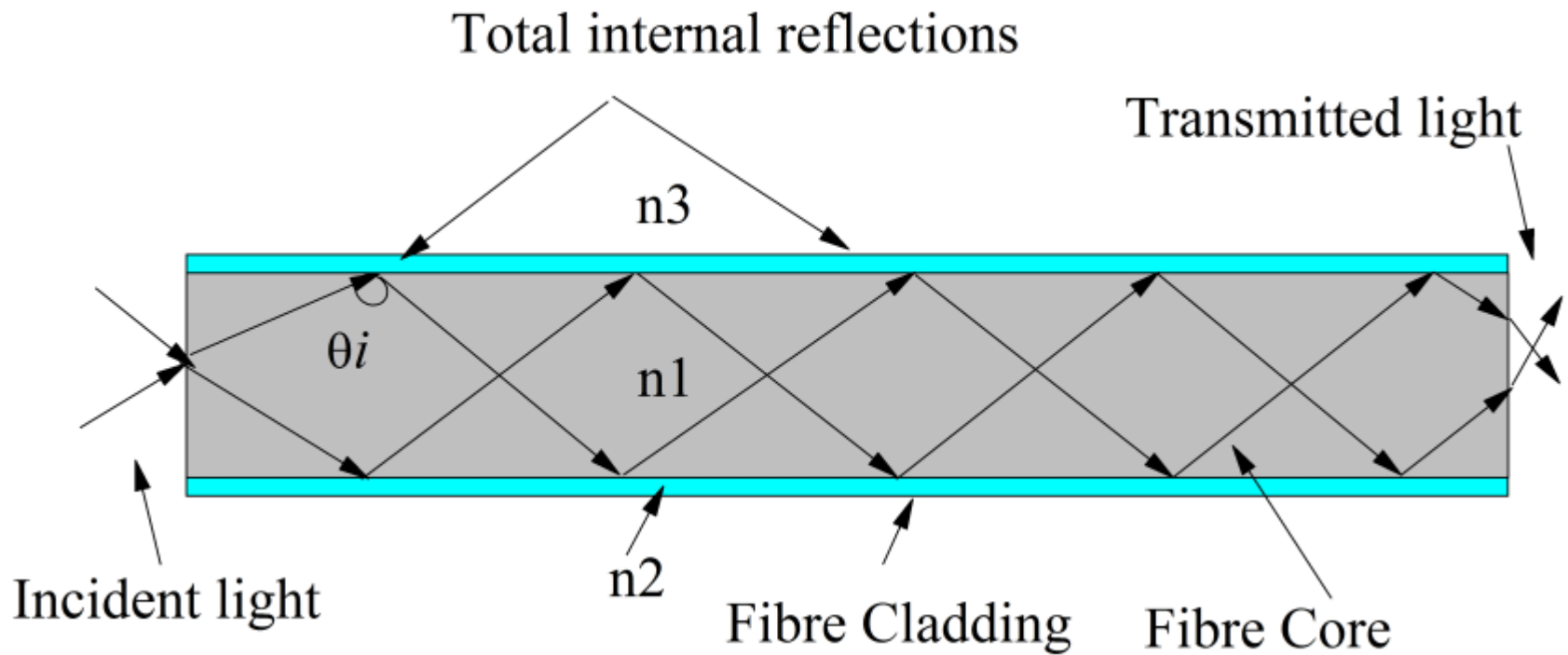

CHAPTER -2

OPTICAL FIBERS AND CABLES

CONSTRUCTION OF OPTICAL FIBER

- A fiber-optic cable is designed to protect the inside fiber core that carries the transmission of a light signal. The construction of a fiber-optic cable includes the fiber core, cladding, primary coating, strength members (or buffer strengthening fibers), and cable jacket.
- **Core:** The fiber core of fiber-optic cable is the central physical medium of the cable that carries the light signal received from an attached light source and delivers it to a receiving device

- **Cladding:** The cladding is a thin layer of glass that surrounds the fiber core, forming a single solid glass fiber that is used for light transmission.
- **Primary Coating:** The primary coating comes after the cladding, and is also known as the primary buffer. It is designed to absorb shocks, provide protection against excessive cable bends, and reinforce the fiber core. This primary coating is basically a layer of plastic

- **Strength Members:** These are placed to protect the core against excessive tension during installation and other crushing forces.
- **Cable Jacket:** The outer layer of any cable is known as the cable jacket.

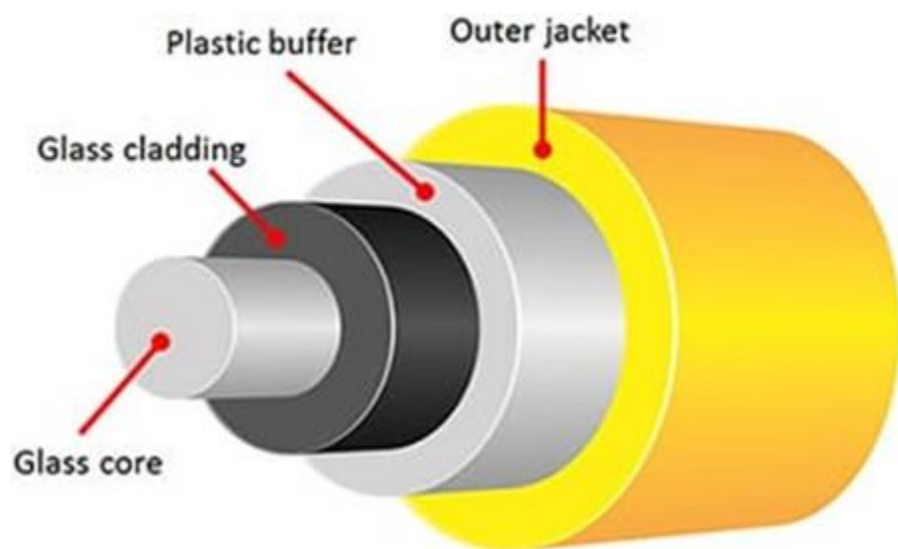

Different types of fibers

1. Multimode fiber
2. Monomode fiber
3. Step index fiber
4. Graded index fiber

- Multimode fiber-Light travels through a large core in many rays called modes (multiple modes). Due to refraction, the rays are reflected from the cladding surface back into the core as they move through the fiber.
- Monomode fiber-Single mode fiber has a much smaller core which forces the light to travel in one ray or mode (a single mode) with little light reflection so the signal will travel further

- **Difference between Single Mode and Multi Mode fiber are given below :**
- Single mode fiber is one in which only one mode propagate through the fiber whereas Multi mode fiber is one in which multiple mode propagate through the fiber.
- Single mode fiber contains small core whereas Multi mode fiber contains large core.
- Single mode fiber employ for long distance communication whereas Multi mode fiber employ for short distance communication.

- Single mode fiber has less attenuation whereas Multi mode fiber has more attenuation.
- Single mode fiber has lower bandwidth whereas Multi mode fiber has higher bandwidth.
- Single mode fiber allows less dispersion whereas Multi mode fiber allows more dispersion.
- Single mode fiber is less costly whereas Multi mode is more costly.
- Single mode fiber is less difficult to work out whereas Multi mode fiber is more difficult to work out.

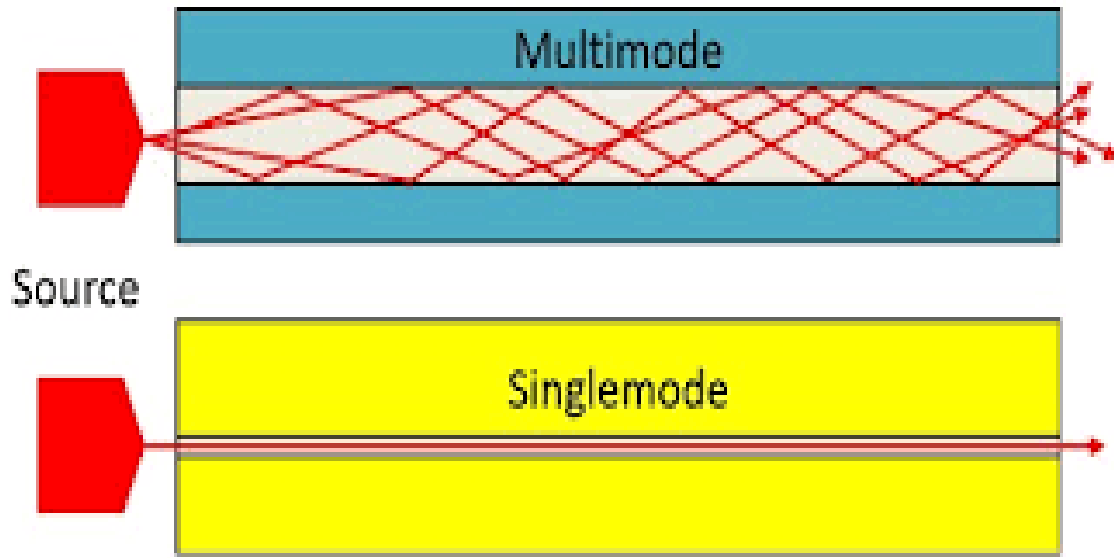

Step index fiber

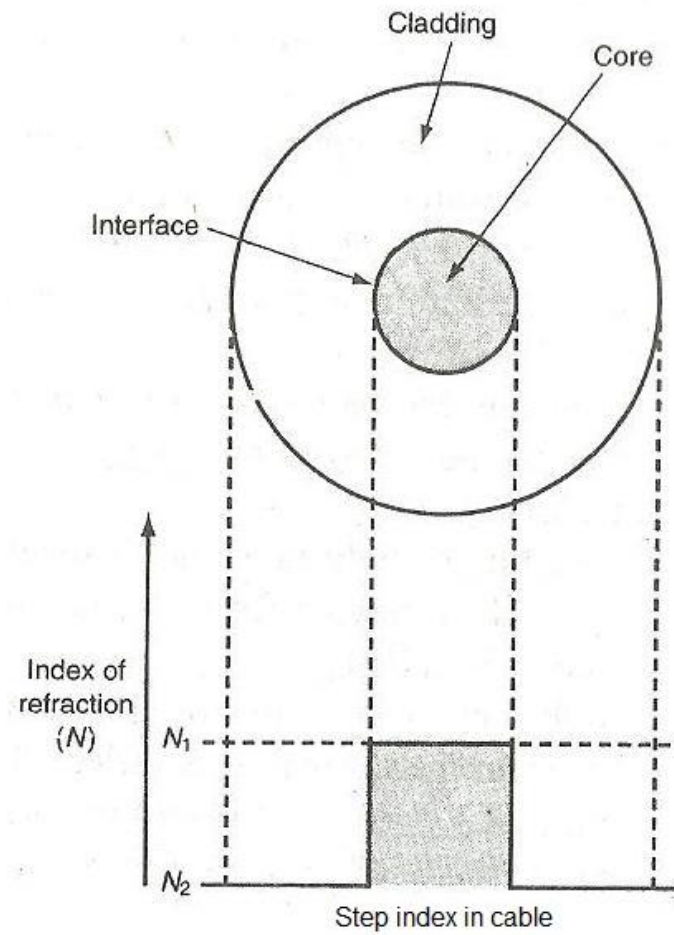

Step index means sharp step in the index of refraction between core and cladding interface. This indicates that in step index, core and cladding have their own constant index of refractions N_1 and N_2 respectively.

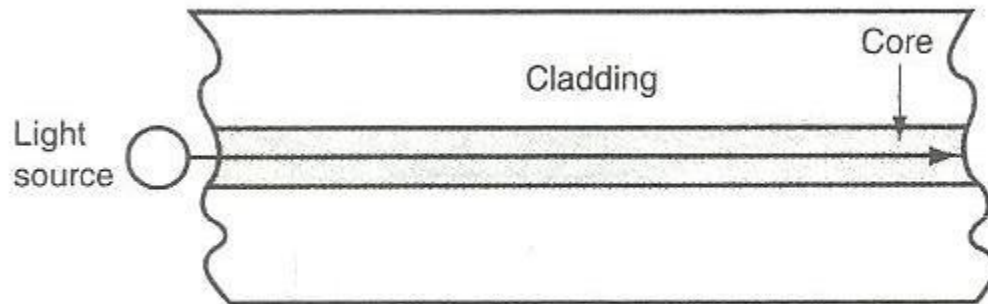

Single mode step index cable

Graded index fiber

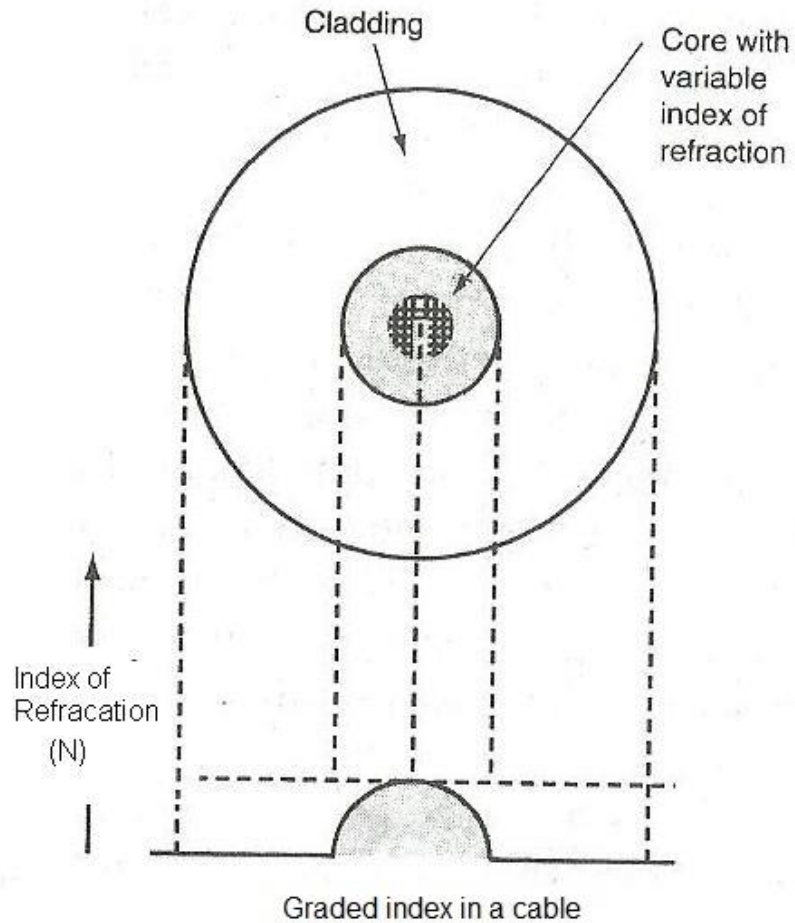

- In graded index, index of refraction is not constant but vary smoothly across the diameter of the core. Index of refraction is increasing as one goes near the center while decreasing near outer core edges. Index of refraction is maximum at the center of the core. Index of refraction is constant for cladding part of the fiber.

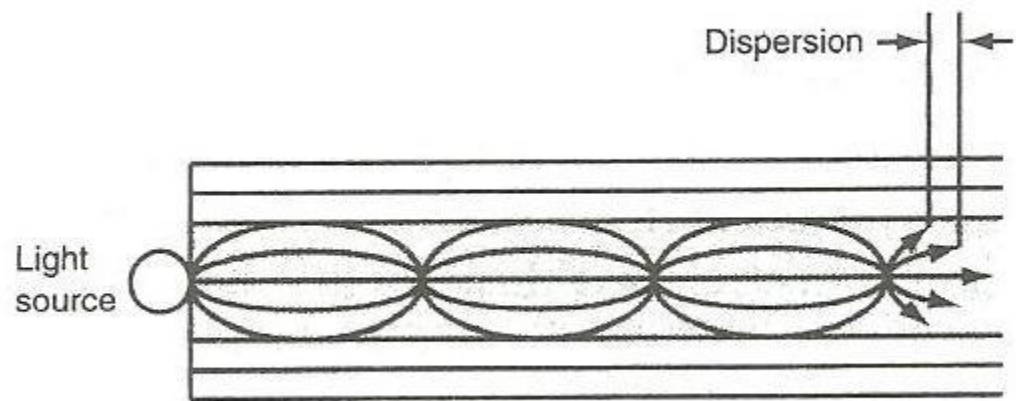

multimode graded index cable

Acceptance angle

- Acceptance angle- the maximum incidence angle of a light ray which can be used for injecting light into a fiber core or waveguide

Acceptance Angle θ

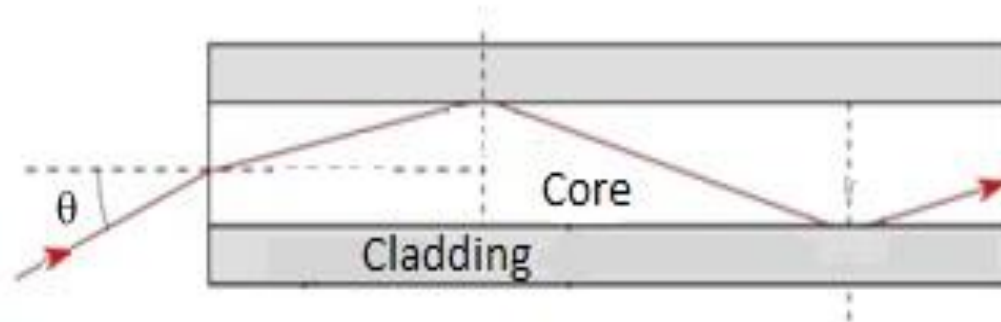

eguruchela.com



Types of Fiber Optic Cables



INDOOR PLENUM



INDOOR/OUTDOOR CABLES



OUTDOOR CABLES



INTERLOCKING ARMOR CABLES

TYPES OF FIBERS (contd.)

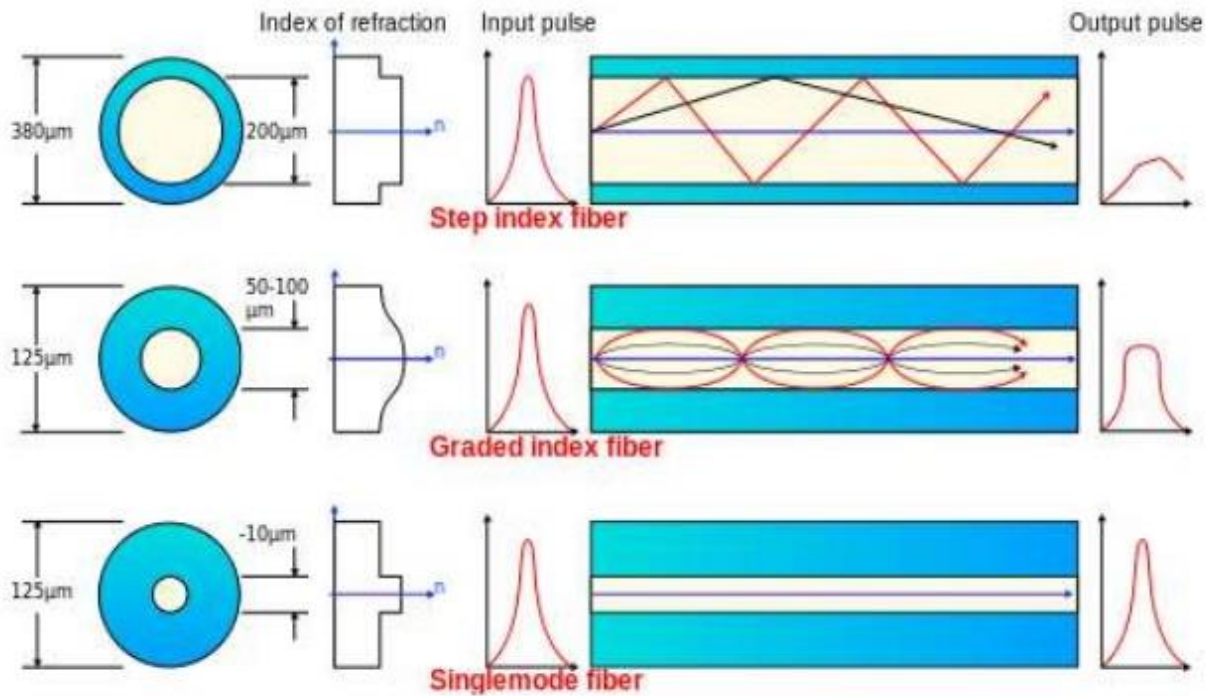

- An **optical fiber connector** terminates the end of an optical fiber, and enables quicker connection and disconnection than splicing. The connectors mechanically couple and align the cores of fibers so light can pass. Better connectors lose very little light due to reflection or misalignment of the fibers

Optical fiber cable connectors



MU Type Fiber Optical Connector



E-2000 Type Fiber Optical Connector



MTRJ Type Fiber Optical Connector



LC Type Fiber Optical Connector



ST Type Fiber Optical Connector



FC Type Fiber Optical Connector



SC Type Fiber Optical Connector

- Optical fiber connectors are used in [telephone exchanges](#), for [customer premises wiring](#), and in [outside plant](#) applications to connect equipment and cables, or to cross-connect cables.
- The fibre optic connector basically consists of a rigid cylindrical barrel surrounded by a sleeve. The barrel provides the mechanical means by which the connector is held in place with the mating half. A variety of methods are used to ensure the connector is held in place, ranging from screw fit, to latch arrangements. The main requirement is that the end of the fibre optic cable is held accurately in place so that the maximum light transfer occurs.

- Fiber splicing is the process of permanently joining two fibers together. Unlike fiber connectors, which are designed for easy reconfiguration on cross-connect or patch panels.
- There are two types of fiber splicing – ***mechanical splicing*** and ***fusion splicing***.

Fiber Optic Splicing Types

Mechanical Splicing

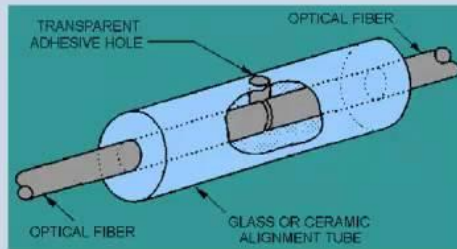

1. Just a mechanical alignment device
2. Holds the two fiber ends in a precisely aligned position
3. Still two separate fibers, NOT continuous

Fusion Splicing

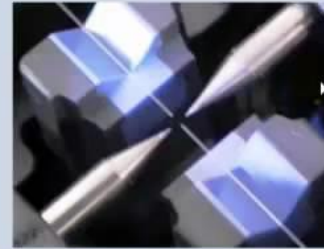

1. Two fiber ends are aligned and then fused or welded together
2. Using heat or electric arc
3. Two fibers become continuous



Fiber Optics For Sale Co.
www.fo4sale.com

Mechanical splicing

- Mechanical splicing doesn't physically fuse two optical fibers together, rather two fibers are held butt-to-butt inside a sleeve with some mechanical mechanism. You will get worse insertion loss and back reflection in mechanical splices than in fusion splices. Mechanical splicing is mostly used for emergency repairs and fiber testing.

Fusion Splicing

- Second type splicing is called fusion splicing. In fusion splicing, two fibers are literally welded (fused) together by an electric arc. Fusion splicing is the most widely used method of splicing as it provides for the lowest insertion loss and virtually no back reflection. Fusion splicing provides the most reliable joint between two fibers. Fusion splicing is done by an automatic machine called [fusion splicer](#) (fusion splicing machines).

Steps for fusion splicing

- There are five basic steps to fusion splicing with a splicing machine.
- Put on the fusion splice protection sleeve.
- Strip the fiber. Strip back all fiber coatings down to the 125um bare fiber. Clean the bare fiber with 99% isopropyl alcohol.
- Cleave the fiber. The fiber needs to be cleaved with a high precision cleaver. Most splicing machines come with a recommended cleaver. Fiber cleaving is a very important step as the quality of the splice will depend on the quality of the cleave.
- Put the fibers into the fiber holders in the fusion splicer. Press the start button to start the fusion splicing
- Heat shrink the protection sleeve to protect the splicing joint.

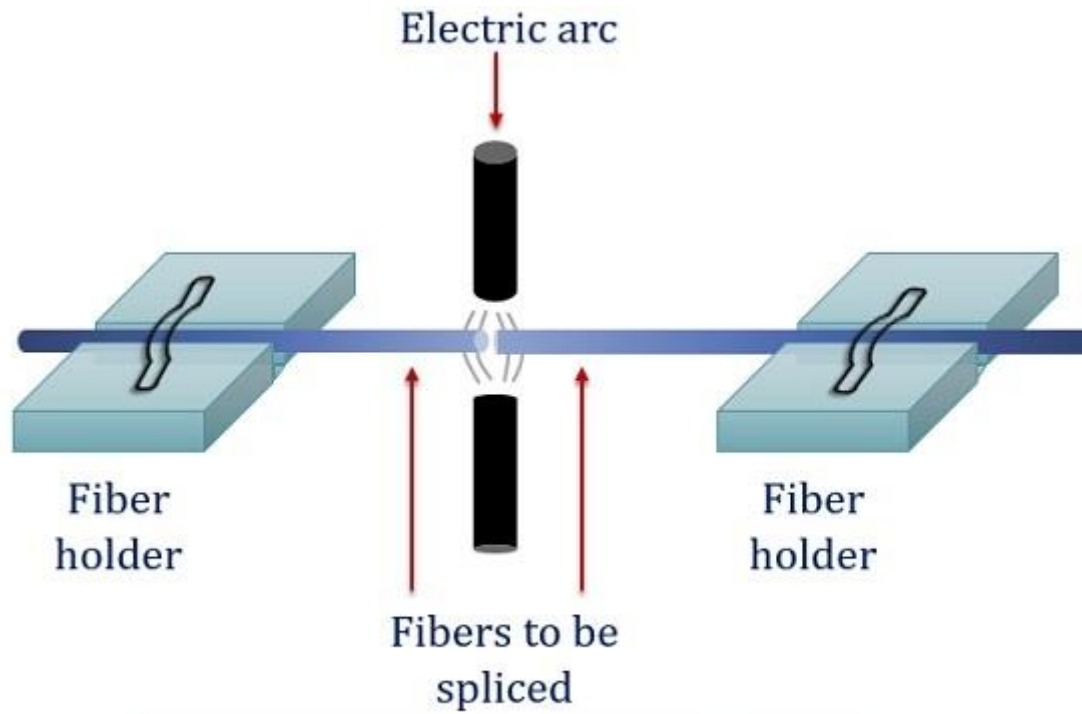

Fusion splicing of optical fiber

Chapter 3

Losses in optical Fibers

Losses in Optical Fibers

- a) Absorption Losses: Scattering Losses, Radiation losses, Connector losses, Bending losses.
- b) b) Dispersion: Types and its effect on data rate.

Absorption Losses

- Absorption loss: The loss of light due to absorption of light energy due to heating of ion impurities is called absorption loss.
- Absorption losses are of two types:
 1. Intrinsic absorption loss:

Intrinsic absorption losses correspond to absorption by fused silica (material used to make fibers)
 2. Extrinsic absorption loss :

Extrinsic absorption is related to losses caused by impurities within silica. Extrinsic absorption results from the presence of impurities. The main source of extrinsic absorption is the presence of water vapours in the silica fibers.

Scattering Losses

- Scattering losses: Scattering means the transfer of some or all of the optical power contained within one propagating mode into a different mode.
- The power may be transferred to a leaky mode which means that the propagation is not within the core but it is within the fiber.
- Scattering losses are:
 - Linear Scattering :-
 - 1) Rayleigh scattering loss
 - 2) Mie scattering loss
 - Non Linear scattering:-
 - 1) SRS(Stimulated Raman Scattering)
 - 2) SBS(Stimulated Brillouin Scattering)

Linear Scattering losses

- **Rayleigh scattering loss:** It occurs because the molecules of silicon dioxide have some freedom when adjacent to one another. Thus, setup at irregular positions and distances with respect to one another.
- Rayleigh scattering is a process in which light is scattered by a small spherical volume of variant refractive index, such as a particle, bubble, droplet, or even a density fluctuation.
- Causes of Rayleigh Scattering:
 - It results from non-ideal physical properties of the manufactured fiber.
 - It results from in-homogeneities in the core and cladding.

Linear Scattering losses

- **Mie Scattering loss:**

Non perfect cylindrical structure of the fiber and imperfections like irregularities in the core-cladding interface, diameter fluctuations, strains and bubbles may create linear scattering which is termed as Mie scattering

- **Causes of Mie Scattering:**

- Occurred due to inhomogeneities in the composition of silica. (i.e. inhomogeneities in the density of SiO_2)
- Irregularities in the core-cladding interface, Difference in core cladding refractive index, Diameter fluctuations
- Due to presence of strains and bubbles.

Non linear scattering losses

- Non-linear scattering loss: The non linear scattering causes the optical power from one mode is transferred in either the forward or backward direction to the same, or other modes, at different frequencies.
- Types of non linear scattering are :
 - a) Stimulated Brillouin Scattering and
 - b) Stimulated Raman Scattering.

Stimulated Brillouin Scattering

- This is defined as the modulation of light through thermal molecular vibration within the fiber. The scattered light contains upper and lower side bands along with incident light frequency.
- The frequency shift is maximum in the backward direction and it is reduced to zero in the forward direction.

Stimulated Raman Scattering:

- The scattered light consists of a scattered photon and a high frequency optical photon.
- This occurs both in the forward and backward direction in the optical fiber. The threshold optical power for Raman scattering is about three orders of magnitude higher than the Brillouin threshold for the given fiber.

Bending losses

- **Bending loss:** The loss of light energy due to bending of fiber is called bending loss.
- Bending losses are of two types:
- **Macro and Micro bending**
 - i) **Macro bending:** Loss is caused due to deformation of fiber axis during cabling process.
 - ii) **Micro bending:** Excessive bending of the cable or fiber may result in loss known as micro bend loss. For single mode fiber attenuation at longer wavelength like 1550 nm is sensitive to bending.

Bending losses

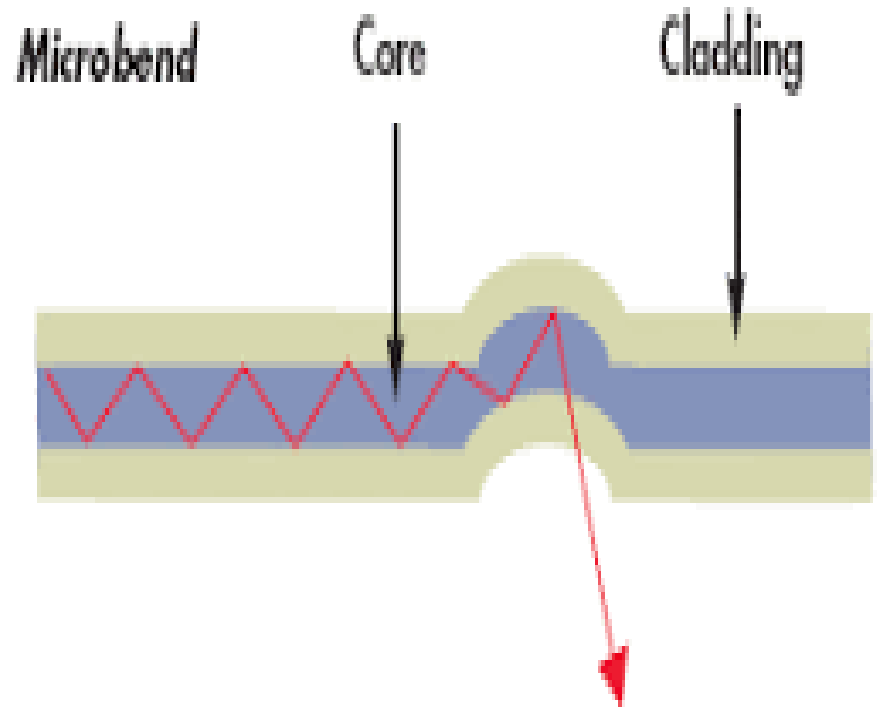
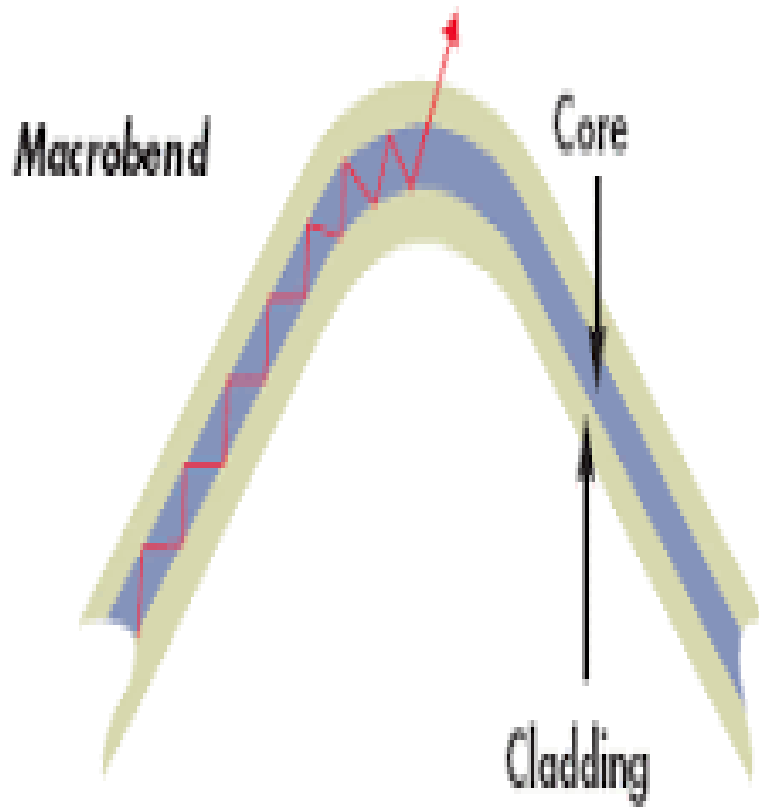

Connector losses

- Connector losses in optical fiber, are the losses of light energy due to insertion of a device (connector) in a transmission line or optical fiber.
- This includes the fresnel reflection loss and fiber misalignment losses
- The major contributors are mutual core displacement and Fiber axis tilt.
- It can occur in both permanent splices and optical connectors.

Fiber to Fiber Misalignment Losses

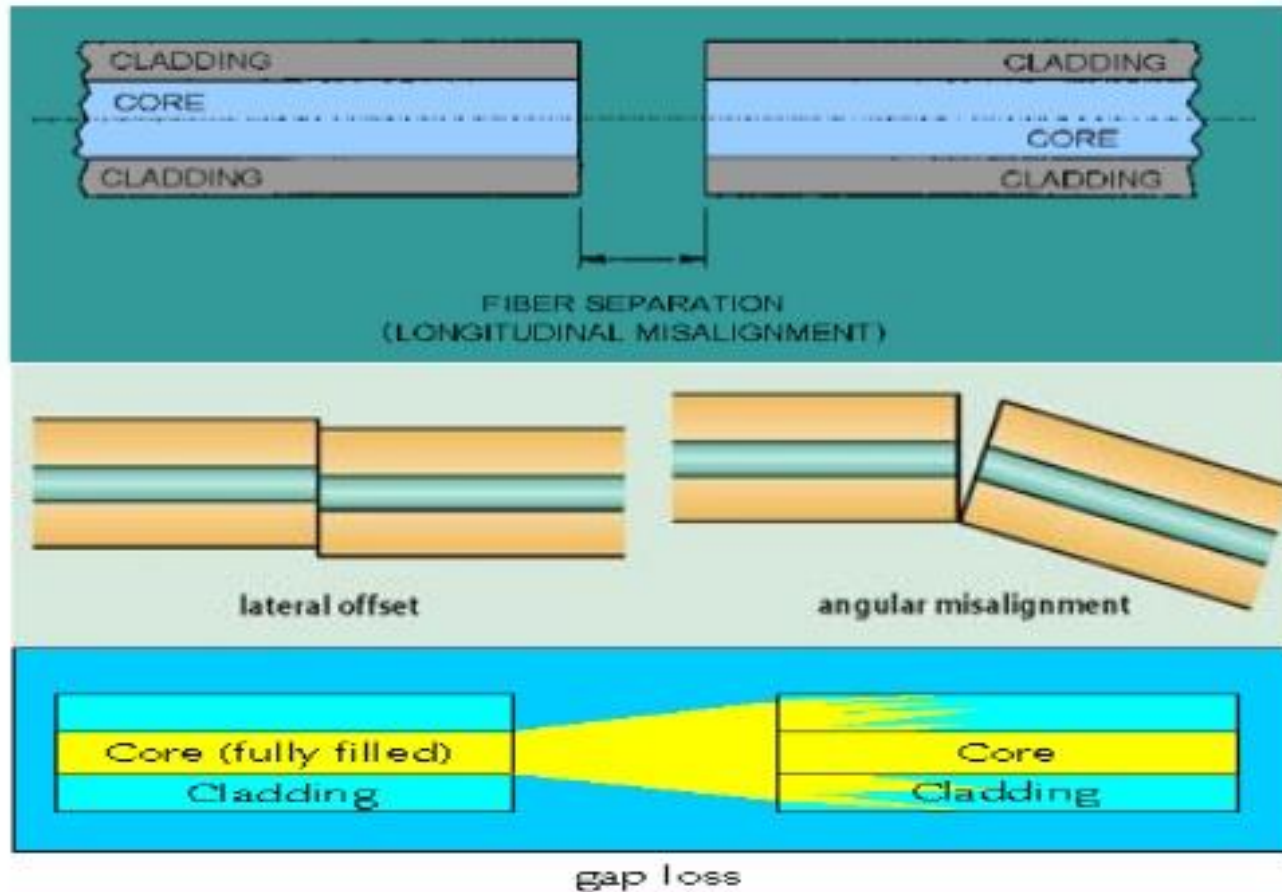

Dispersion

- Dispersion is the spreading out of a light pulse in time as it propagates down the fiber.
- Types of Dispersion:
- In optical fiber different dispersions are
 - Intramodal dispersion: it is further of two types-
 - I. Material dispersion and
 - II. Waveguide dispersion.
 - Intermodal dispersion

Dispersion



As a pulse travels down a fiber, dispersion causes pulse spreading. This limits the distance and the bit rate of data on an optical fiber.



1 0 1

Symbols become
unrecognizable

Types of dispersion

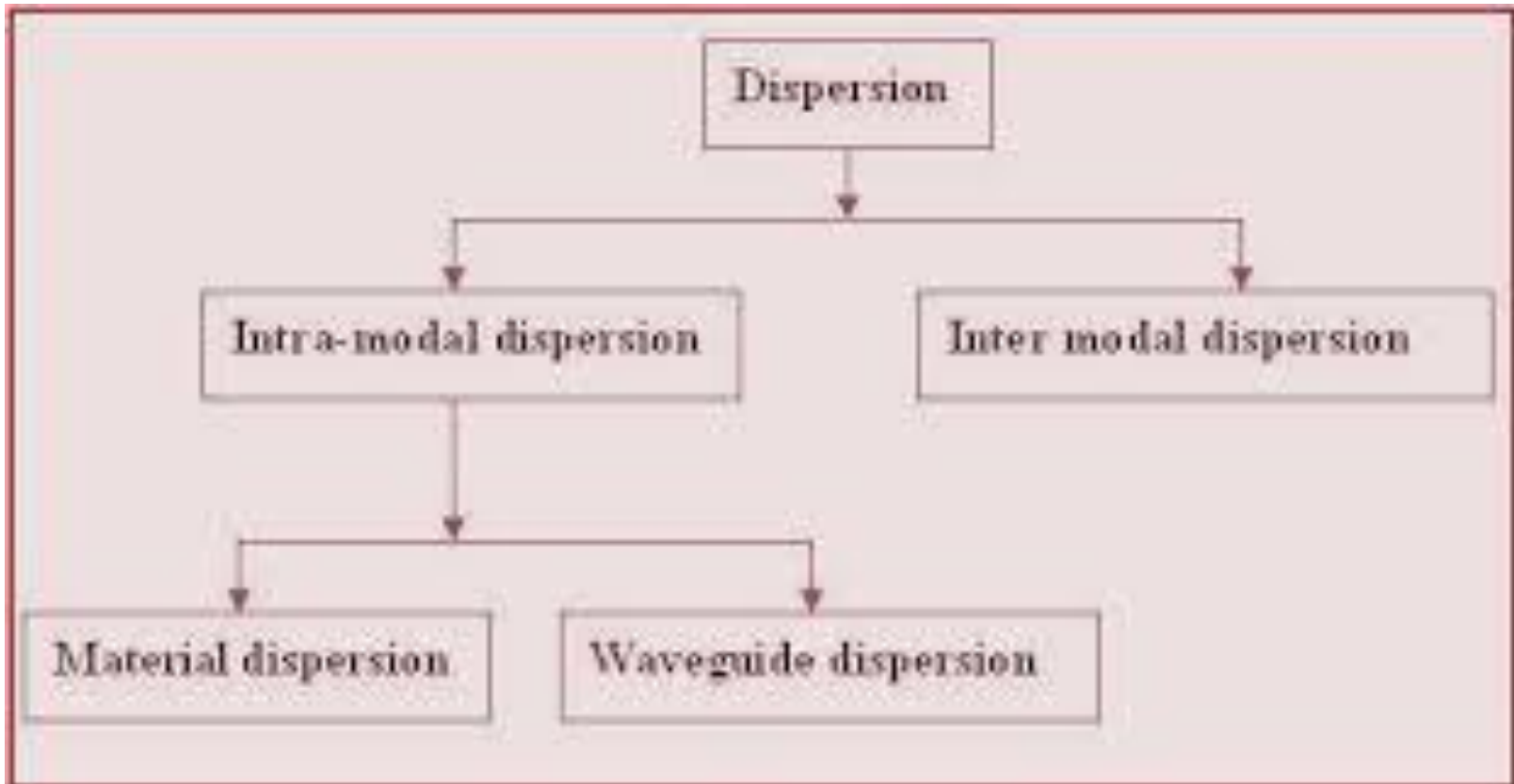

Intramodal Dispersion

- Pulse broadening within a single mode is called as intramodal dispersion or chromatic dispersion.
- It is wavelength dependent and group velocity is a function of wavelength, it is also called as group velocity dispersion (GVD).
- It is further categorized as
 - I. Material dispersion
 - II. Waveguide dispersion

MATERIAL DISPERSION

- It is the pulse spreading due to material.
- It arises from variation of refractive index of the core material as a function of wavelength.
- Material dispersion is a property of glass as a material and will always exist irrespective of the structure of the fiber.
- Material dispersion is a type of chromatic dispersion. Chromatic dispersion is the pulse spreading that arises because the velocity of light through a fiber depends on its wavelength.

WAVEGUIDE DISPERSION

- Waveguide dispersion is only important in single mode fibers.
- It is caused by the fact that some light travels in the fiber cladding compared to most light travels in the fiber core.
- The fiber cladding has lower refractive index than fiber core, light ray that travels in the cladding travels faster than that in the core.
- This dispersion due to 20% light propagating in the cladding travels faster than light confined to the core.
- The amount of waveguide dispersion depends on the structure of the fiber and can be varied by altering the parameters such as NA, core radius etc.

Dispersion

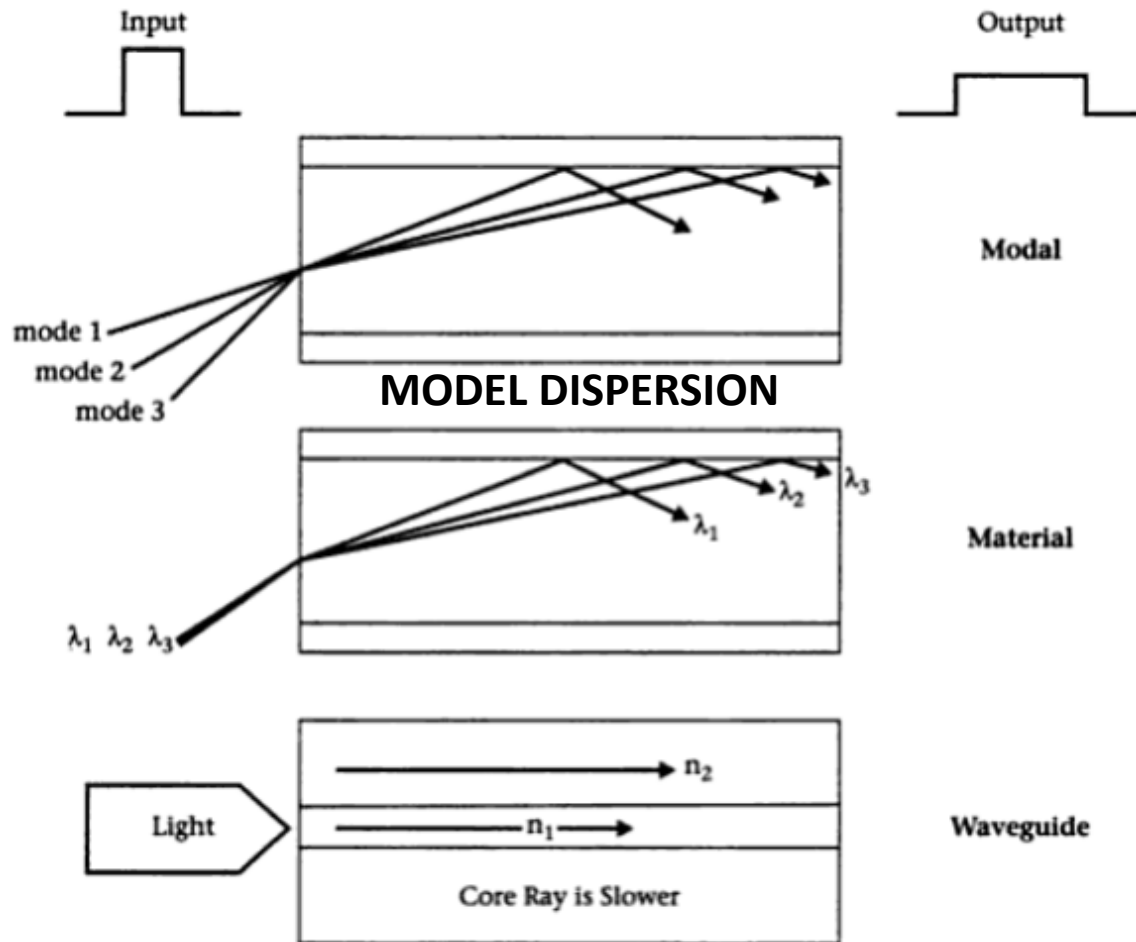

Intermodal dispersion or Modal Dispersion

- Dispersion caused by multipath propagation of light energy is referred to as intermodal dispersion or modal dispersion.
- Multimode fibers can guide many different light modes since they have much larger core size.
- Each mode enters the fiber at a different angle and thus travels at different paths in the fiber.
- Each mode ray travels a different distance as it propagates, the ray arrive at different times at the fiber output.

Intermodal dispersion or Modal Dispersion

- The light pulse spreads out in time which can cause signal overlapping.
- In digital transmission, we use light pulse to transmit bit 1 and no pulse for bit 0. When the light pulse enters fiber it is breakdown into small pulses carried by individual modes. At the output individual pulses are recombined and since they are overlapped receiver sees a long pulse causing pulse broadening.
- Modal dispersion is not a problem in single mode fibers.

Dispersion and Bit Rate

Fibre output with no Dispersion

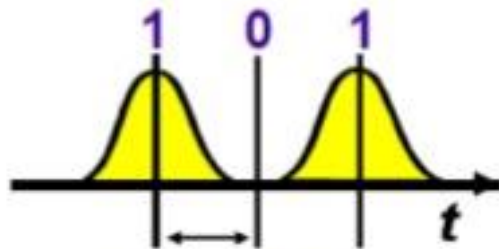

Bit interval "T"

Fibre output with Dispersion

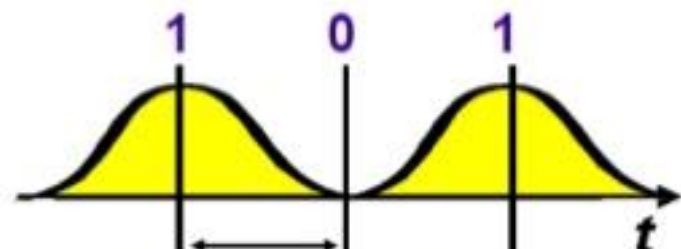

Longer bit interval

- The higher dispersion the longer the bit interval which must be used
- A longer the bit interval means fewer bits can be transmitted per unit of time
- A longer bit interval means a lower bit rate

Conclusion: The higher the dispersion the lower the bit rate

OTDR(Optical Time Domain Reflectometer)

- OTDR: A measurement technique which provides the loss characteristics of an optical link down its entire length giving information on the length dependence loss
- It is a fiber optic instrument used to characterize, troubleshoot and maintain optical telecommunication networks.
- OTDR testing is performed by transmitting and analyzing pulsed laser light traveling through an optical fiber.
- The measurement is said to be unidirectional as the light is insert at extremity of a fiber optic cable link.

OTDR

- An OTDR launches pulses of light into the line fiber of an optical network and monitors the signal.
- As the pulse propagates down the fiber it becomes weaker due to losses.
- The measured signal decreases accordingly.
- The rate of decrease of signal for a fiber represents the fiber loss.

OTDR

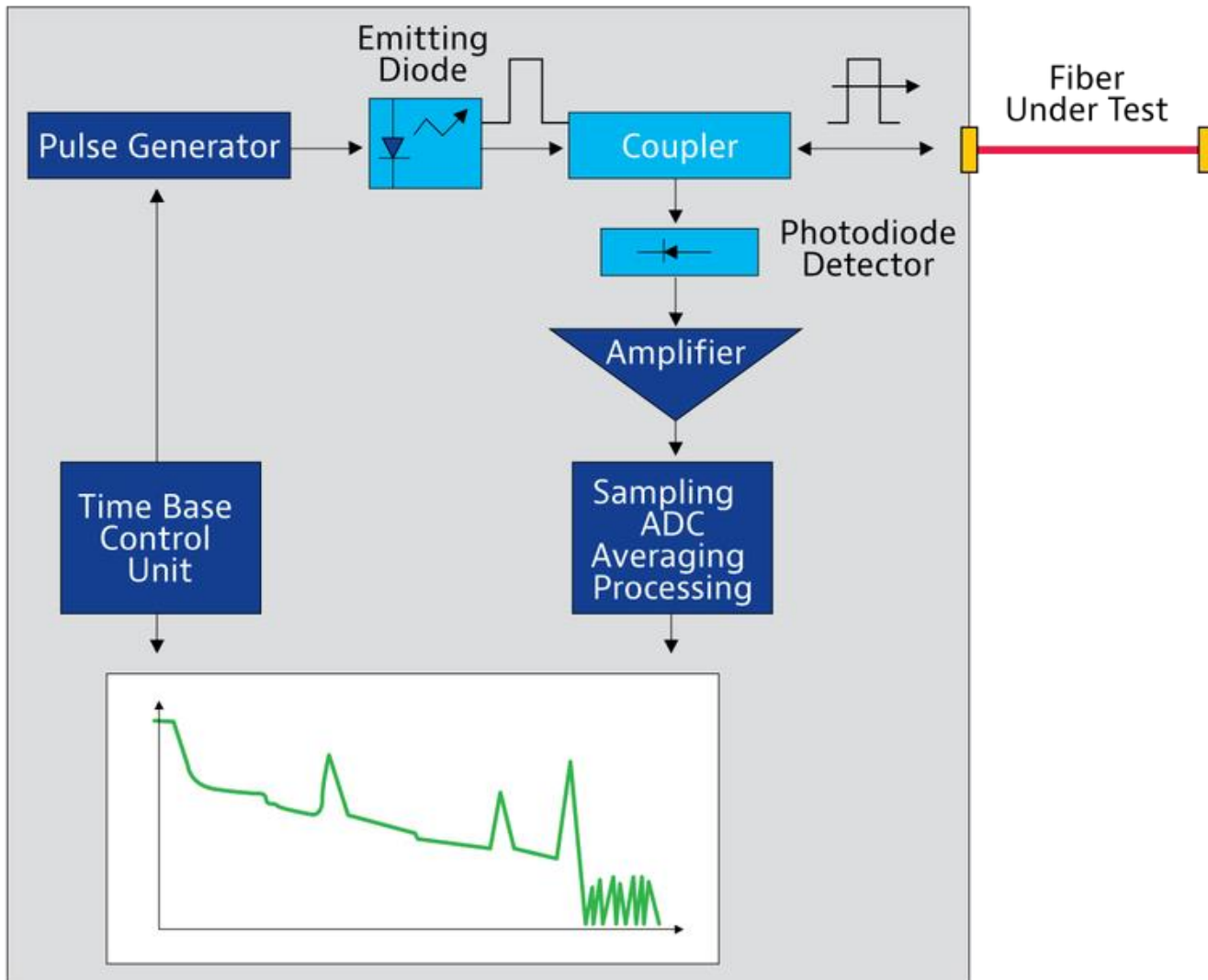

Chapter 4

Optical sources

- **optical source: 1.** In optical communications, a device that converts an electrical signal into an optical signal. *Note:* The two most commonly used optical sources are light-emitting diodes (LEDs) and laser diodes
- **LED** -An LED or a Light Emitting Diode is semiconductor device that emits light due to Electroluminescence effect. An LED is basically a PN Junction Diode, which emits light when forward biased.

Few advantages of LEDs over incandescent and CFL light sources are mentioned below:

- Low Power Consumption
- Small Size
- Fast Switching
- Physically Robust
- Long Lasting

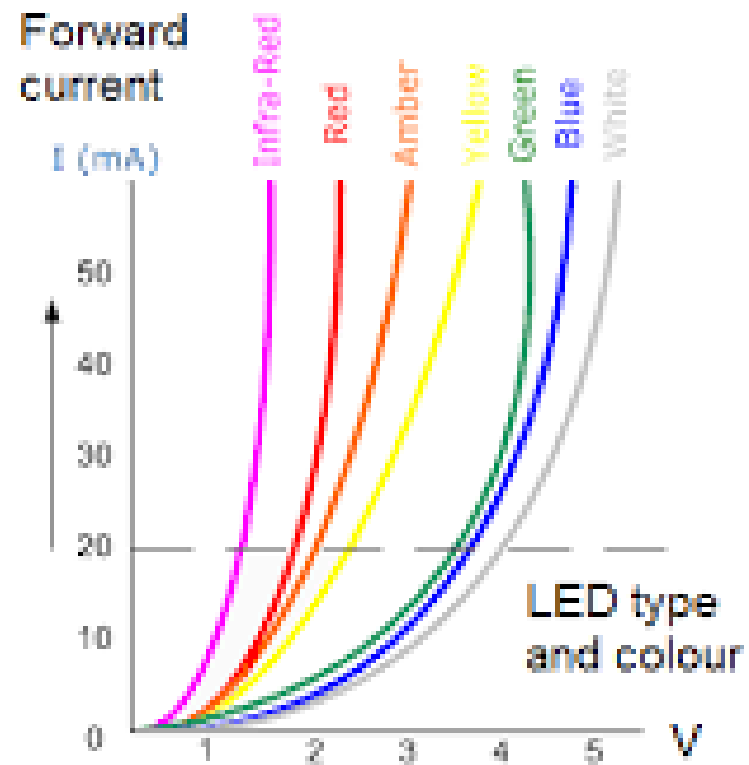
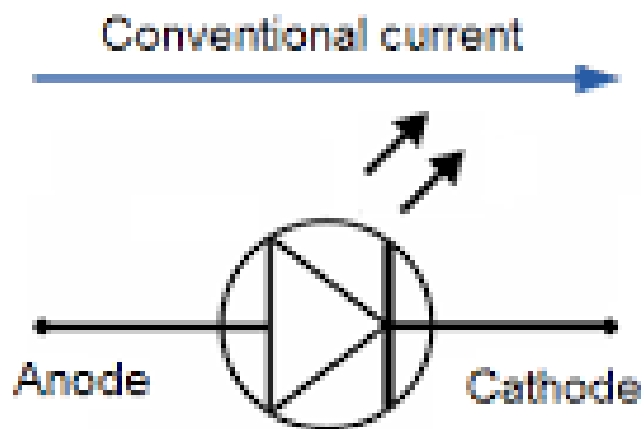

Characteristics of LED (Light Emitting Diode)

- **LED current / voltage specification** -LEDs are current driven devices and the level of light is a function of the current - increasing the current increases the light output. It is necessary to ensure that the maximum current rating is not exceeded. This could give rise to excessive heat dissipation within the LED chip itself which could result in reduced light output and reduced operating lifetime.

Characteristics of LED (Light Emitting Diode)

- **LED current / voltage specification**
- LEDs are current driven devices and the level of light is a function of the current - increasing the current increases the light output. It is necessary to ensure that the maximum current rating is not exceeded. This could give rise to excessive heat dissipation within the LED chip itself which could result in reduced light output and reduced operating lifetime.

LEDs will have a given voltage drop across them which is dependent upon the material used. The voltage will also be slightly dependent upon the level of current, so the current will be stated for this.

Working of LED

- The light emitting diode simply, we know as a diode. When the diode is forward biased, then the electrons & holes are moving fast across the junction and they are combining constantly, removing one another out. Soon after the electrons are moving from the n-type to the p-type silicon, it combines with the holes, then it disappears. Hence it makes the complete atom & more stable and it gives the little burst of energy in the form of a tiny packet or photon of light.

-

How does an LED emit light?

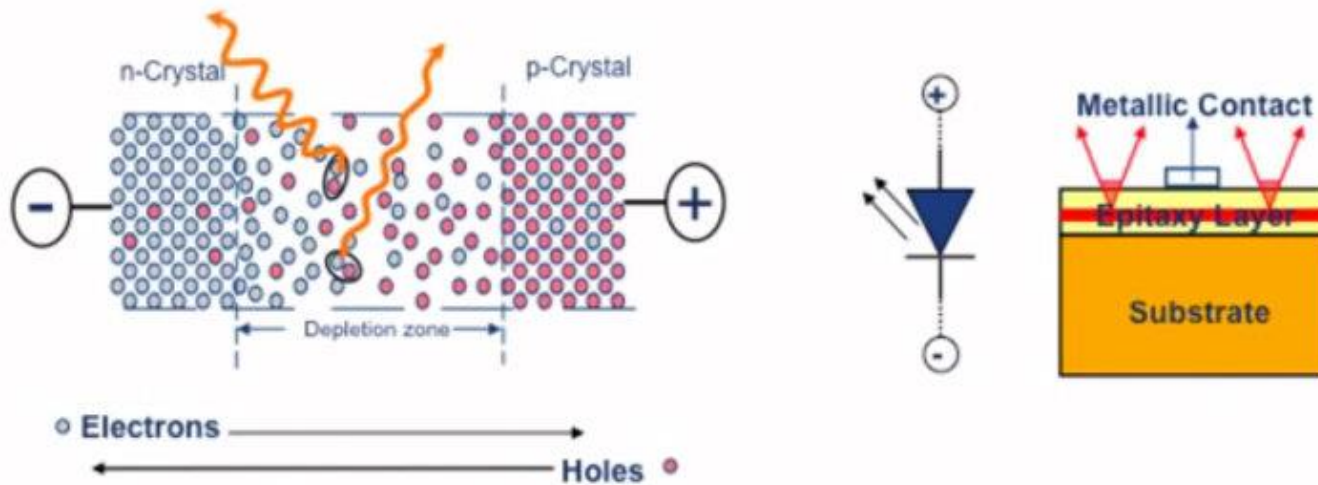

- LED chip's PN junction is biased in a forward direction;
- Free charge is forced (overcome V_f) into the depletion zone;
- Electrons recombine with holes, and some of these recombination's emit light;
- The color of the light is based on the material selection, which directly affects the forward voltage of the LED.

LASER

- Laser” is an acronym for “Light Amplification by Stimulated Emission of Radiation”,
- **WORKING-** A laser is created when the electrons in atoms in special glasses, crystals, or gases absorb energy from an electrical current or another laser and become “excited.” The excited electrons move from a lower-energy orbit to a higher-energy orbit around the atom’s nucleus. When they return to their normal or “ground” state, the electrons emit photons (particles of light).
-

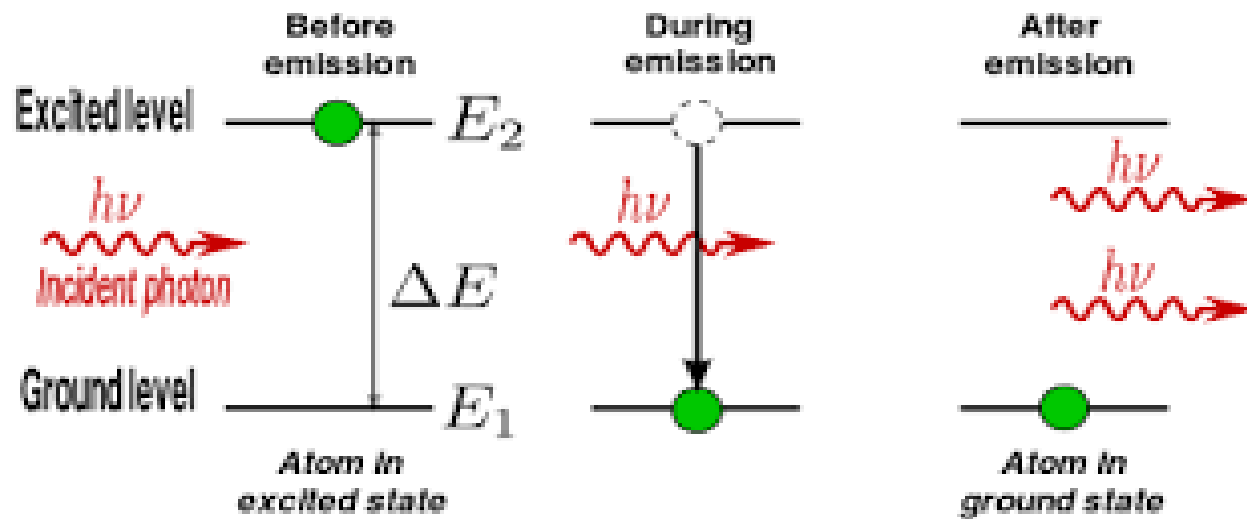

$$E_2 - E_1 = \Delta E = h\nu$$

Characteristics of Laser

Laser light has four unique characteristics that differentiate it from ordinary light: these are

- Coherence
- Directionality
- Monochromatic
- High intensity
- Coherence

- **1.Coherence**

- In ordinary light sources (lamp, sodium lamp and torch light), the electron transition occurs naturally.. Therefore, photons emitted by an ordinary light source are out of phase.
- In laser, the electron transition occurs artificially. All the photons emitted in laser have the same energy, frequency, or wavelength. Hence, the light waves of laser light have single wavelength or color.
- Thus, light generated by laser is highly coherent.

- **2.Directionality**

- In conventional light sources (lamp, sodium lamp and torchlight), photons will travel in random direction. Therefore, these light sources emit light in all directions.

On the other hand, in laser, all photons will travel in same direction. Therefore, laser emits light only in one direction. This is called directionality of laser light

3.Monochromatic

- Monochromatic light means a light containing a single color or wavelength. The photons emitted from ordinary light sources have different energies, frequencies, wavelengths, or colors. Hence, the light waves of ordinary light sources have many wavelengths or colors. Therefore, ordinary light is a mixture of waves having different frequencies or wavelengths.

- **High Intensity**
- Intensity of a wave is the energy per unit time flowing through a unit normal area. In an ordinary light source, the light spreads out uniformly in all directions.
- laser light has greater intensity when compared to the ordinary light.

Different LED Structures

- There are two basic configurations which can be used.
- ***Edge emitting LED structure:*** This form of LED structure emits light in a plane parallel to the junction of the PN junction. In this configuration the light can be confined to a narrow angle.
- ***Surface emitting LED structure:*** This form of LED structure emits light perpendicular to the plane of the PN junction.

LED Structures

1. Planar LED
2. Dome LED
3. Surface emitter LED

Planar LED

- Simplest of the structures that are available.
- Fabricated by liquid or Fabricated by liquid or vapour phase epitaxial processes over GaAs surface
- TIR (total internal reflection) limits the Radiance low

Planar LED

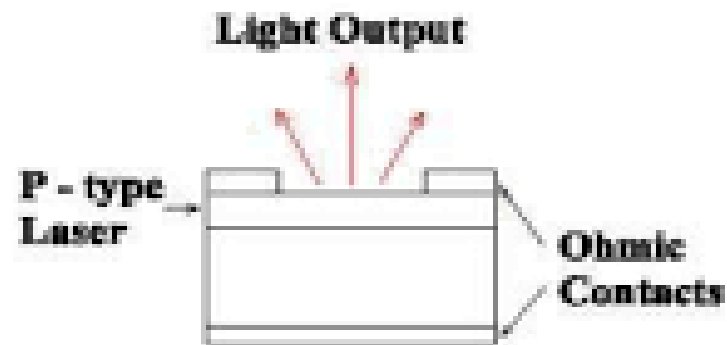

- Dome LED
- A hemisphere of n-type GaAs around p-region.
- Higher external power efficiency than planar LED.

Dome LED

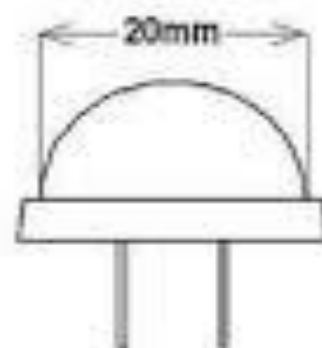

Surface Emitter LED

- Used an etched well in a GaAs substrate in order to prevent heavy absorption of to prevent heavy absorption of emitted radiation.
- Low thermal impedance thermal impedance in active in active region allowing high current densities and giving high radiance emission into optical fiber.

Injection Laser Diode

- A laser diode, also known as an *injection laser* or *diode laser*, is a semiconductor device that produces coherent radiation (in which the waves are all at the same frequency and phase) in the visible or infrared (IR) spectrum when current passes through it. Laser diodes are used in optical fiber systems, compact disc (CD) players.

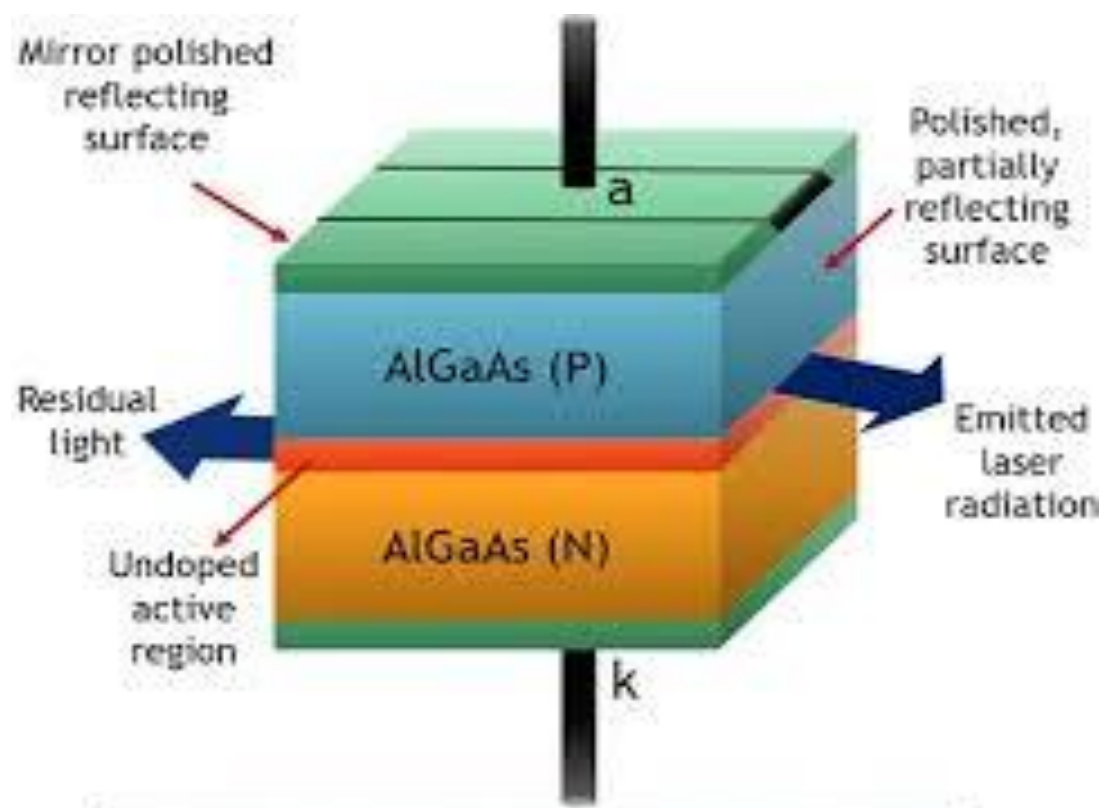

Constructional detail of laser diode

Comparison of LED And ILD

specification	Light Emitting Diode	Laser Diode
Working operation	It emits light by spontaneous emission.	It emits light by stimulated emission.
Coherent/Incoherent	The emitted light is incoherent i.e. photons are in random phase among themselves.	It possesses a coherent beam with identical phase relation of emitted photons.
Output power	Emitted light power is relatively low, Linearly proportional to drive current	Output power is high (Few mW to GW) , Proportional to current above the threshold

Ease of use	Easier	Harder
Lifetime	Longer	Long
Spectral width	Wider, 25 to 100 nm (10 to 50 THz)	Narrower, $<10^{-5}$ to 5 nm (<1 MHz to 2 MHz)
Modulation Bandwidth	Moderate, Tens of KHz to tens of MHz	High, Tens of MHz to tens of GHz
Available Wavelength	0.66 to 1.65 μ m	0.78 to 1.65 μ m

Bias/Current	It requires small applied bias and operates under relatively low current densities.	It requires high driving power and high injected current density is needed.
Coupled power	Moderate	High
Speed	Slower	Faster
Output pattern	Higher	Lower
Fiber Type	Multimode only	Singlemode and multimode

E/O Conversion Efficiency	10 to 20 %	30 to 70 %
Eye Safety	Generally considered eye-safe	Must be rendered eye-safe, especially for $\lambda < 1400$ nm
Cost	Low	Moderate to High